

ROBE

ROBIN[®] Viva

ROBIN[®] Viva

Wireless DMX
CRMX™

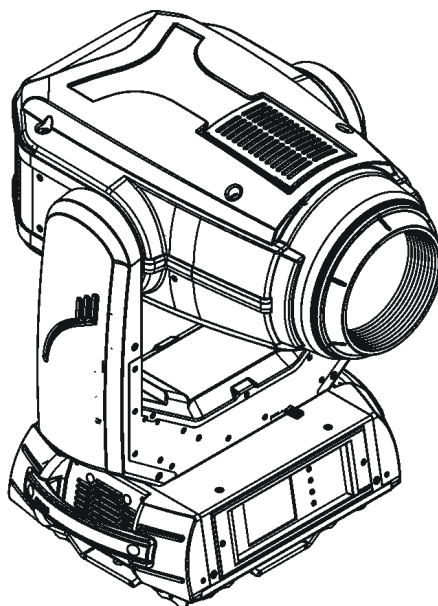

 **ROBIN[®]**
Innovative Technology

USER MANUAL

Version 1.4

ROBE[®] lighting s.r.o. • Czech Republic • www.robe.cz

Robin Viva

Table of contents

1. Safety instructions	3
2. Operating determination	4
3. Fixture exterior view	5
4. Installation	6
4.1 Connection to the mains	6
4.2 Replacing colour filters and gobos	6
4.3 Replacing the frost	8
4.4 Rigging the fixture	9
4.5 DMX-512 connection.....	11
4.6 Ethernet connection	12
5. Remotely controllable functions	14
6. Control menu map	15
7. Control menu	18
7.1 Tab "Address"	19
7.2 Tab "Information"	20
7.3 Tab "Personality"	21
7.4 Tab "Manual Control".....	23
7.5 Tab "Stand-alone"	23
7.6 Tab "Service"	24
8. RDM	26
9. Wireless DMX operation	27
10. Error and information messages	27
11. Technical Specifications	29
12. Maintenance and cleaning	31
12.1 Disposing of the product	32
13. Photometric diagrams	32
14. ChangeLog	33

CAUTION!
Keep this device away from rain and moisture!
Unplug mains lead before opening the housing!

**FOR YOUR OWN SAFETY, PLEASE READ THIS USER MANUAL CAREFULLY
BEFORE YOU INITIAL START - UP!**

1. Safety instructions

Every person involved with installation and maintenance of this device have to:

- be qualified
- follow the instructions of this manual

CAUTION!
Be careful with your operations.
With a high voltage you can suffer
a dangerous electric shock when touching the wires!

This device has left our premises in absolutely perfect condition. In order to maintain this condition and to ensure a safe operation, it is absolutely necessary for the user to follow the safety instructions and warning notes written in this manual.

Important:

The manufacturer will not accept liability for any resulting damages caused by the non-observance of this manual or any unauthorized modification to the device.

Please consider that damages caused by manual modifications to the device are not subject to warranty.

Never let the power-cord come into contact with other cables! Handle the power cord and all connections with the mains with particular caution!

Make sure that the available voltage is not higher than stated on the rear panel.

WARNING! This unit does not contain an ON/OFF switch. Always disconnect power input cable to completely remove power from unit when not in use or before cleaning or servicing the unit.

Make sure that the power cord is never crimped or damaged by sharp edges. Check the device and the power-cord from time to time.

Always disconnect from the mains, when the device is not in use or before cleaning it. Only handle the power-cord by the plug. Never pull out the plug by tugging the power cord.

This device falls under protection class I. Therefore it is essential to connect the yellow/green conductor to earth. The electric connection, repairs and servicing must be carried out by a qualified employee.

Do not connect this device to a dimmer pack.

During the initial start-up some smoke or smell may arise. This is a normal process and does not necessarily mean that the device is defective.

Do not touch the device's housing bare hands during its operation (housing becomes hot)!
For replacement use fuses of same type and rating only.

Warning! Risk Group 2 LED product according to EN 62471.
LED light emission. Risk of eye injury!
Do not look straight at the fixture's LED source during operation. The intense light beam may damage your eyes.

Do not view the light output with optical instruments or any device that may concentrate the beam.

2. Operating determination

This device is a moving head for creating decorative effects and was designed for indoor use only. This device is for professional use only. It is not for household use.

If the device has been exposed to drastic temperature fluctuation (e.g. after transportation), do not switch it on immediately. The arising condensation water might damage your device. Leave the device switched off until it has reached room temperature.

Do not shake the device. Avoid brute force when installing or operating the device.

Never lift the fixture by holding it at the projector-head, as the mechanics may be damaged. Always hold the fixture at the transport handles.

When choosing the installation-spot, please make sure that the device is not exposed to extreme heat, moisture or dust. There should not be any cables lying around. You endanger your own and the safety of others!

Make sure that the area below the installation place is blocked when rigging, derigging or servicing the fixture.

Always fix the fixture with an appropriate safety rope. Fix the safety rope at the correct holes only.

Only operate the fixture after having checked that the housing is firmly closed and all screws are tightly fastened.

The maximum ambient temperature 45°C must never be exceeded.

CAUTION!
The lens has to be replaced when it is obviously damaged, so that its function is impaired, e. g. due to cracks or deep scratches!

Operate the device only after having familiarized with its functions. Do not permit operation by persons not qualified for operating the device. Most damages are the result of unprofessional operation!

Do not block the front objective lens with any object when the fixture is under operation.

The fixture housing never must be covered with cloth or other materials.

Please use the original packaging if the device is to be transported.

Please consider that unauthorized modifications on the device are forbidden due to safety reasons!

If this device will be operated in any way different to the one described in this manual, the product may suffer damages and the guarantee becomes void. Furthermore, any other operation may lead to dangers like short-circuit, burns, electric shock, burns etc.

CAUTION!
To avoid damage of the internal parts of the fixture head, never let the sunlight or othert light source lights directly to the front lens, even when the fixture is not working !

3. Fixture exterior view

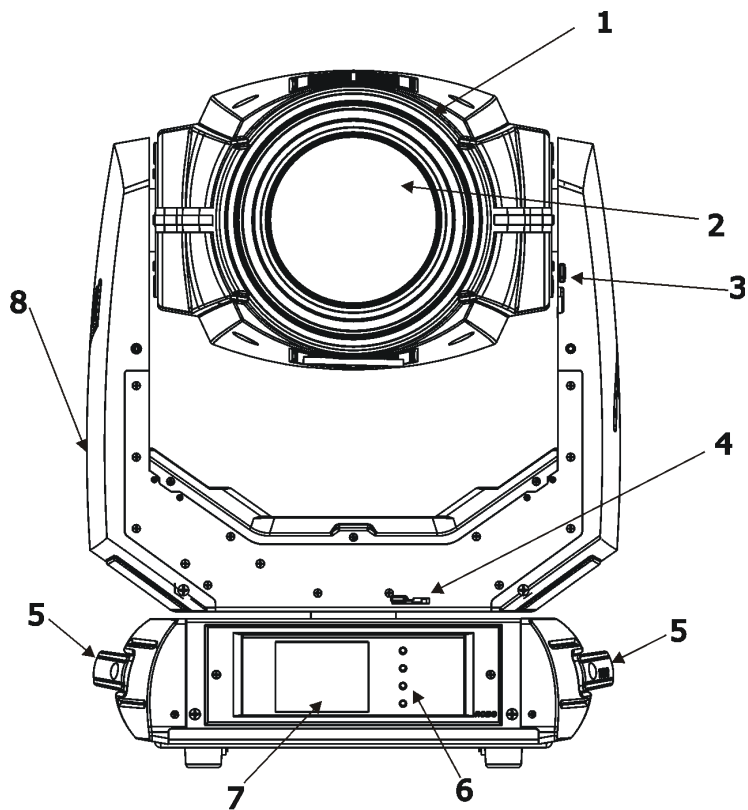

- 1 - Head
- 2 - Front lens
- 3 - Tilt lock
- 4 - Pan lock
- 5 - Handles
- 6 - Control buttons
- 7 - Touch screen
- 8 - Yoke

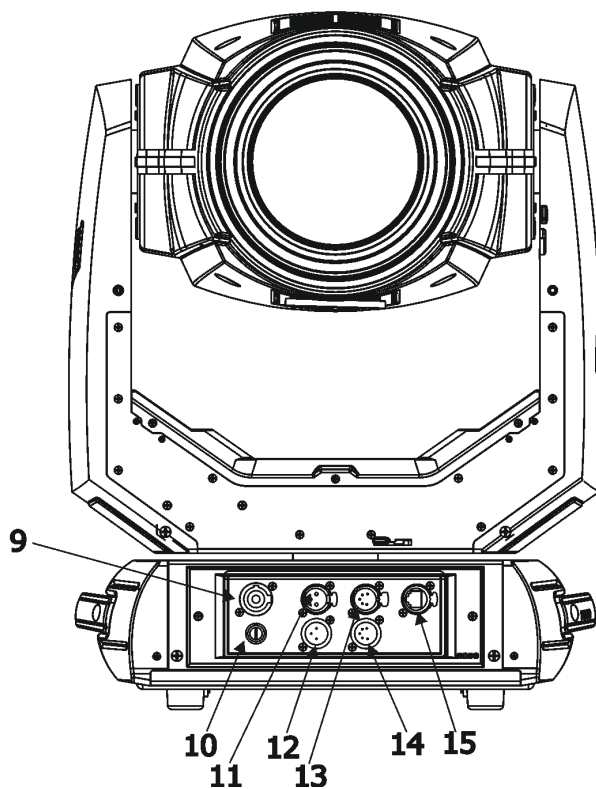

- 9 - Power (Neutrik PowerCon)
- 10 - Fuse holder
- 11 - DMX OUT (3-pin)
- 12 - DMX IN (3-pin)
- 13 - DMX OUT (5-pin)
- 14 - DMX IN (5-pin)
- 15 - Ethernet (RJ45)

The head should be locked for transportation- the tilt lock latch (3) and the pan lock latch (4) have to be in the locked positions. To unlock the head, move these latches to unlock positions before operating the fixture. The ENTER/DISPLAY ON button also serves for switching the display on when the fixture is disconnected from the mains.

4. Installation



Fixtures must be installed by a Qualified electrician in accordance with all national and local electrical and construction codes and regulations.

4.1 Connection to the mains

For protection from electric shock, the fixture must be earthed!

The Robin Viva is equipped with auto-switching power supply that automatically adjusts to any 50-60Hz AC power source from 100-240 Volts.

Power cord is enclosed to the fixture. Install a suitable plug on the power cord if needed, note that the cores in the power cord are coloured according to the following table. The earth has to be connected!

If you have any doubts about proper installation, consult a qualified electrician.

Core (EU)	Core (US)	Connection	Plug Terminal Marking
Brown	Black	Live	L
Light blue	White	Neutral	N
Yellow/Green	Green	Earth	

4.2 Replacing colour filters and gobos

DANGER!

**Install the colour filters or gobos with the device switched off only.
Unplug from mains before!**

Colour filters

1. Disconnect the fixture from mains and allow it to cool.
2. Remove the top plastic cover of the head by loosening the 4 quarter-turn fasteners on the cover.
3. Turn the colour wheel 2 to the desired position. The dichroic filters are fixed on the colour wheel 2 by the magnets.
4. Release the dichroic filter from the colour wheel by inclining it from its position to break the power of the magnet. Protect the glass filter with a piece of paper or clout.
5. Insert a new dichroic filter into the colour wheel 2.
6. Place the top cover back before applying power.

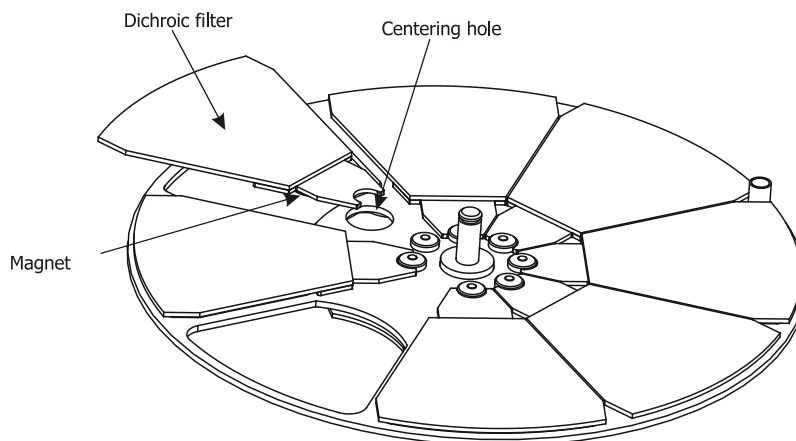

Rotating gobos

1. Disconnect the fixture from mains and allow it to cool.
2. Remove the plastic cover of the head by loosening the 4 quarter-turn fasteners on the cover.
3. Gently pull up the gobo holder (3) from the rotation gobo wheel.
4. Remove the spring lock (1) with an appropriate tool (e.g. small-bladed screwdriver) and remove it.
Do not touch the surface of the pattern of the glass gobo with bare fingers.
5. Remove the original gobo (2) and insert the new one (glazy side towards the light source).
The Robe gobo has a small position point (8) at its edge which has to aimed at the position point (4) on the gobo holder (4). Insert the spring lock to secure correct gobo position in the gobo holder.
6. Insert the gobo holder back under the distance slots (6, 7) into rotating gobo wheel in this way, that its position point (4) has to aimed at a small toothlike projection (5) on the edge of the rotating gobo wheel.

Important! When inserting the gobo holder back to the rotating gobo wheel, one of the adjacent gobo holder has to be oriented according to the same rule, it means that its position point (4) has to aimed at the toothlike projection (5) on the edge of the rotating gobo wheel. You have keep both marks (4) and (5) side by side when rotating the gobo wheel to the position allows inserting the gobo holder back.

5. Replace the plastic cover before applying power.

6. Use the menu Service to fine adjust replaced gobo (Service -> Calibration -> Calibrate effects -> R. Gobo Index 1 ...R. Gobo Index 6).

Note. The magnet (9) of the gobo holder has the same function as the position point (4) on the rest of gobo holders.

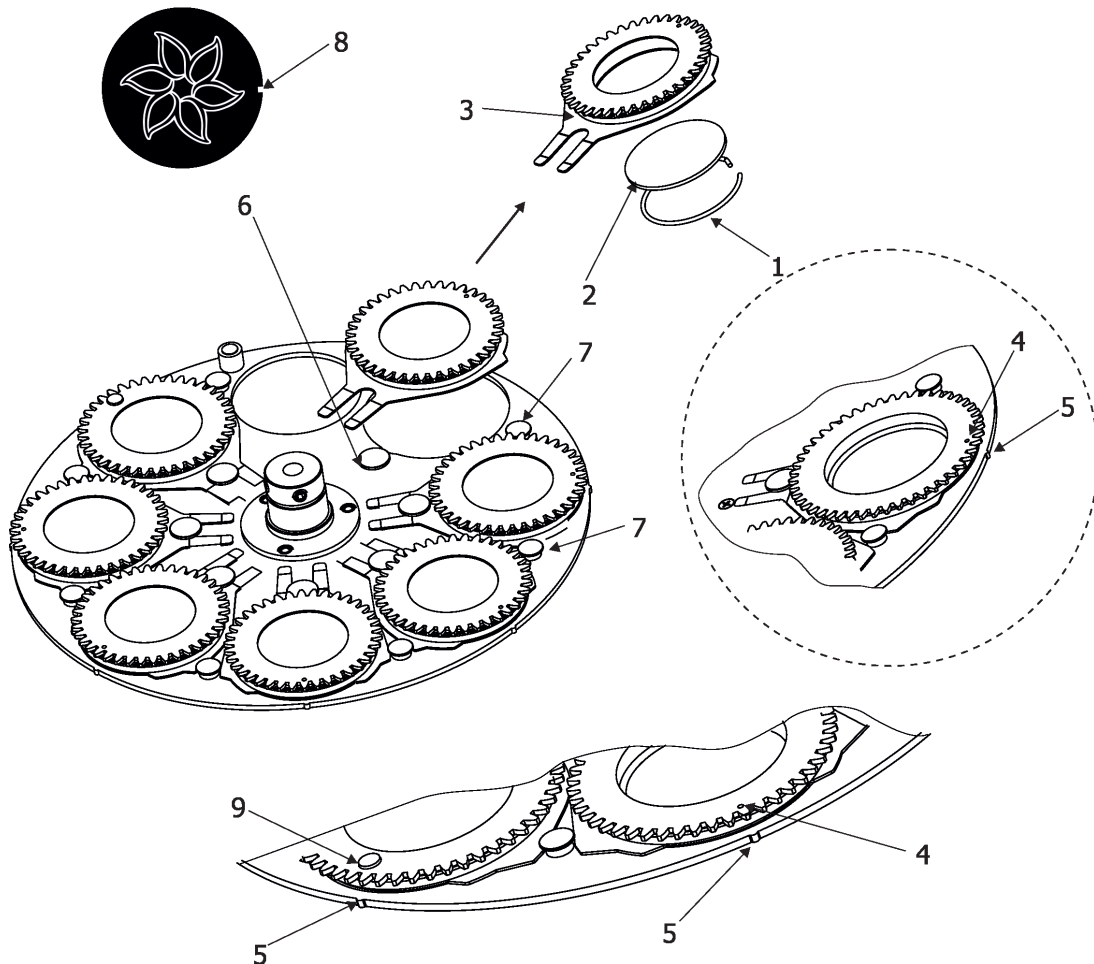

4.3 Replacing the frost

***Install the frost module with the device switched off only.
Unplug from mains before!***

To replace the frost module.

1. Disconnect the fixture from mains and allow it to cool for 10 minutes.
2. Remove plastic cover of the head by loosening the 4 quarter-turn fasteners on the cover to get access to the frost module (1).

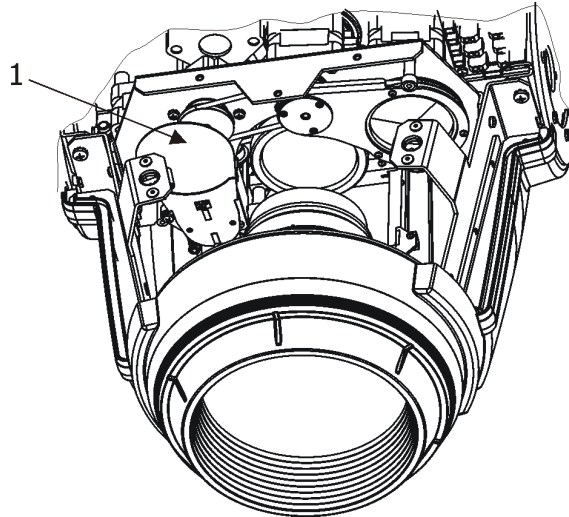

3. The holder (2) of the frost film is fastened to the frost holder (6) by means of the four magnets (3). Grip the holder (2) and carefully tilt it out to break a force of magnets (3) on the frost holder (6).

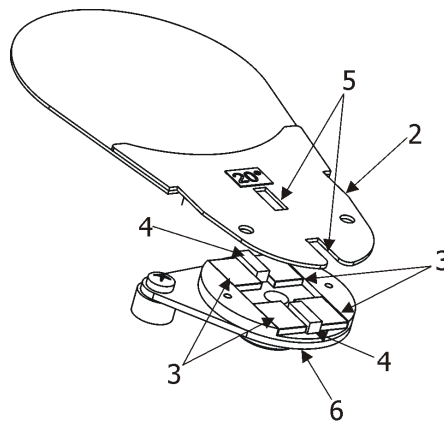

4. Insert a new frost module into the frost holder (6). Check, that both slots (5) snapped correctly into two protrusions (4) on the holder (6)
5. Place the plastic cover back on the fixture before applying power.

4.4 Rigging the fixture

The installation of the fixture has to be built and constructed in a way that it can hold 10 times the weight for 1 hour without any harming deformation.

The installation must always be secured with a secondary safety attachment, e.g. an appropriate catch net. This secondary safety attachment must be constructed in a way that no part of the installation can fall down if the main attachment fails.

When rigging, derigging or servicing the fixture staying in the area below the installation place, on bridges, under high working places and other endangered areas is forbidden.

The operator has to make sure that safety-relating and machine-technical installations are approved by an expert before taking into operation for the first time and after changes before taking into operation another time.

The operator has to make sure that safety-relating and machine-technical installations are approved by an expert after every four year in the course of an acceptance test.

The operator has to make sure that safety-relating and machine-technical installations are approved by a skilled person once a year.

The projector should be installed outside areas where persons may walk by or be seated.

IMPORTANT! OVERHEAD RIGGING REQUIRES EXTENSIVE EXPERIENCE, including (but not limited to) calculating working load limits, installation material being used, and periodic safety inspection of all installation material and the fixture. If you lack these qualifications, do not attempt the installation yourself, but instead use a professional structural rigger. Improper installation can result in bodily injury or damage to property.

The fixture has to be installed out of the reach of people.

If the fixture shall be lowered from the ceiling or high joists, professional trussing systems have to be used. The fixture must never be fixed swinging freely in the room.

Caution: Fixtures may cause severe injuries when crashing down! If you have doubts concerning the safety of a possible installation, do not install the moving head!

Before rigging make sure that the installation area can hold a minimum point load of 10 times the fixture's weight.

Danger of fire !
When installing the device, make sure there is no highly inflammable material (decoration articles, etc.) in a distance of min. 0.5 m.

CAUTION!
Use 2 appropriate clamps to rig the fixture on the truss.
Follow the instructions mentioned at the bottom of the base.
Make sure that the device is fixed properly! Ensure that the structure (truss) to which you are attaching the fixtures is secure.

The fixture can be placed directly on the stage floor or rigged in any orientation on a truss without altering its operation characteristics .

For securing a fixture to the truss, install a safety wire that can hold at least 10 times the weight of the fixture. Use only the safety wire with screw-on carabine. Pull the safety wire through the safety attachment point on the bottom of the base and around the truss as shown on the pictures below.

Truss installation

1. Bolt each clamp (1) to the omega holder (3) with M12 bolt and lock nut through the hole in the holder.
2. Fasten the omega holders on the bottom of the base by inserting both quick-lock fasteners (4) into the holes of the base and tighten fully clockwise.
3. Pull the safety wire (2) through the attachment point and around the truss (6).

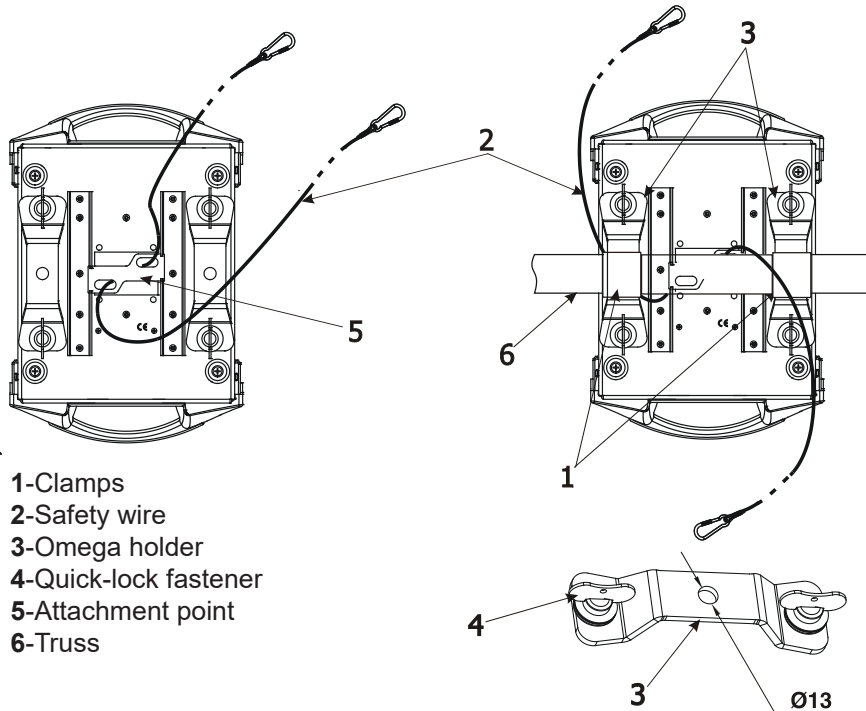

Alternatively, fixtures handles can be used for safety attachment

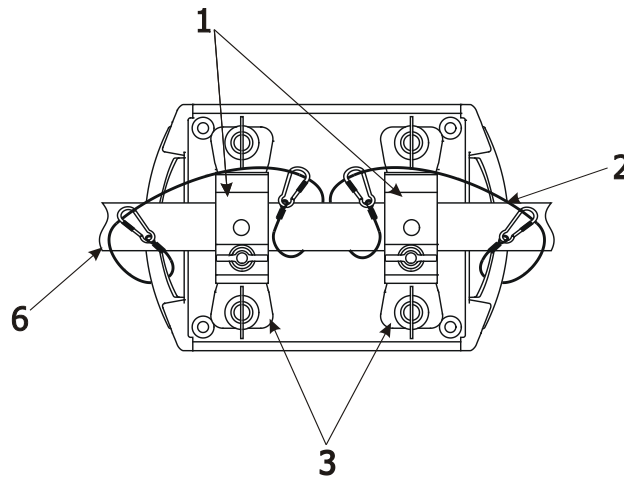

**When installing fixtures side-by-side,
avoid illuminating one fixture with another!**

DANGER TO LIFE!
Before taking into operation for the first time, the installation has to be approved by an expert!

4.5 DMX-512 connection

The fixture is equipped with both 3-pin and 5-pin XLR sockets for DMX input and output. The sockets are wired in parallel.

Only use a shielded twisted-pair cable designed for RS-485 and 3-pin or 5-pin XLR-plugs and connectors in order to connect the controller with the fixture or one fixture with another.

DMX - output

XLR mounting-sockets (rear view):

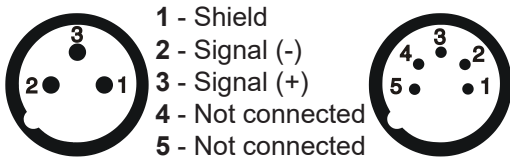

DMX-input

XLR mounting-plugs (rear view):

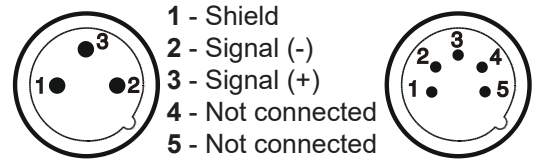

If you are using the standard DMX controllers, you can connect the DMX output of the controller directly with the DMX input of the first fixture in the DMX-chain. If you wish to connect DMX-controllers with other XLR-outputs, you need to use adapter-cables.

Building a serial DMX-chain:

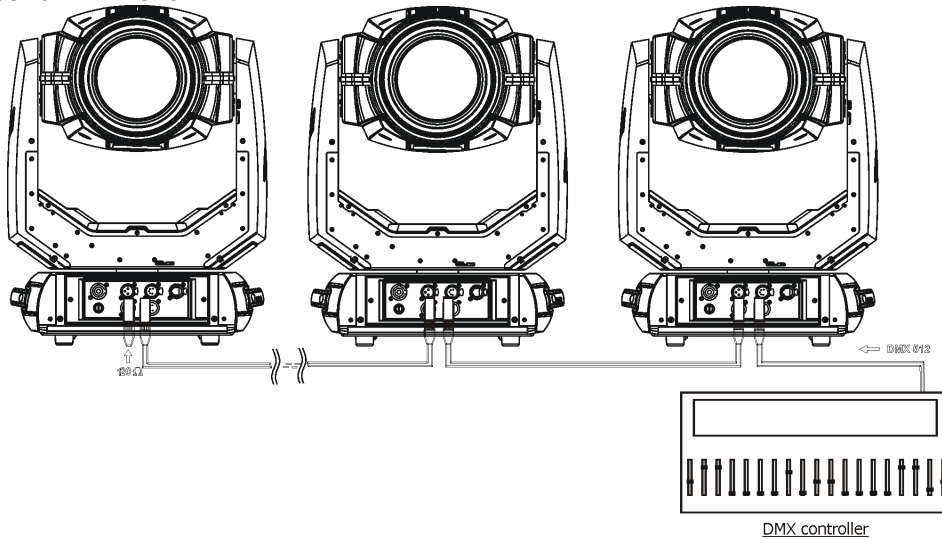

Connect the DMX-output of the first fixture in the DMX-chain with the DMX-input of the next fixture. Always connect one output with the input of the next fixture until all fixtures are connected.

Caution: At the last fixture, the DMX-cable has to be terminated with a terminator. Solder a 120 Ω resistor between Signal (-) and Signal (+) into a 3-pin XLR-plug and plug it in the DMX-output of the last fixture.

4.6 Ethernet connection

The fixtures on a data link are connected to the Ethernet with ArtNet communication protocol. The control software running on your PC (or light console) has to support Art-Net protocol.

Art-Net communication protocol is a 10 Base T Ethernet protocol based on the TCP/IP. Its purpose is to allow transfer of large amounts of DMX 512 data over a wide area using standard network technology.

IP address is the Internet protocol address. The IP uniquely identifies any node (fixture) on a network.

The Universe is a single DMX 512 frame of 512 channels.

The Robin Viva is equipped with 8-pin RJ-45 socket for Ethernet input. Use a network cable category 5 (with four "twisted" wire pairs) and standard RJ-45 plugs in order to connect the fixture to the network.

RJ-45 socket (front view):

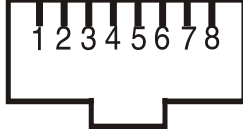

- | | |
|------------------|------------------|
| 1- TD+ | 5- Not connected |
| 2- TD- | 6- RX- |
| 3- RX+ | 7- Not connected |
| 4- Not connected | 8- Not connected |

RJ-45 plug (front view):

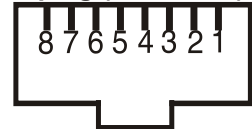

Patch cables that connect fixtures to the hubs or LAN sockets are wired 1:1, that is, pins with the same numbers are connected together:



If only the fixture and the computer are to be interconnected, no hubs or other active components are needed. A cross-cable has to be used:



If the fixture is connected with active Ethernet socket (e.g. switch) the network icon  will appear at the bottom right corner of the screen:

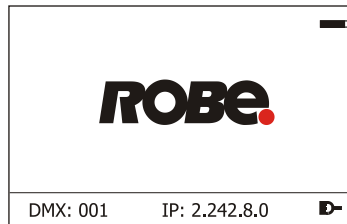

Direct Ethernet operation

Connect the Ethernet inputs of all fixtures with the Ethernet network.

Option "Artnet (gMal or gMA2)" has to be selected from "Ethernet Mode" menu on the fixture.

Set IP address (002.xxx.xxx.xxx / 010.xxx.xxx.xxx) and the Universe.

(DMX address=129)
IP address=002.168.002.004
Universe=1

(DMX address=31)
IP address=002.168.002.003
Universe=1

(DMX address=1)
IP address=002.168.002.002
Universe=1

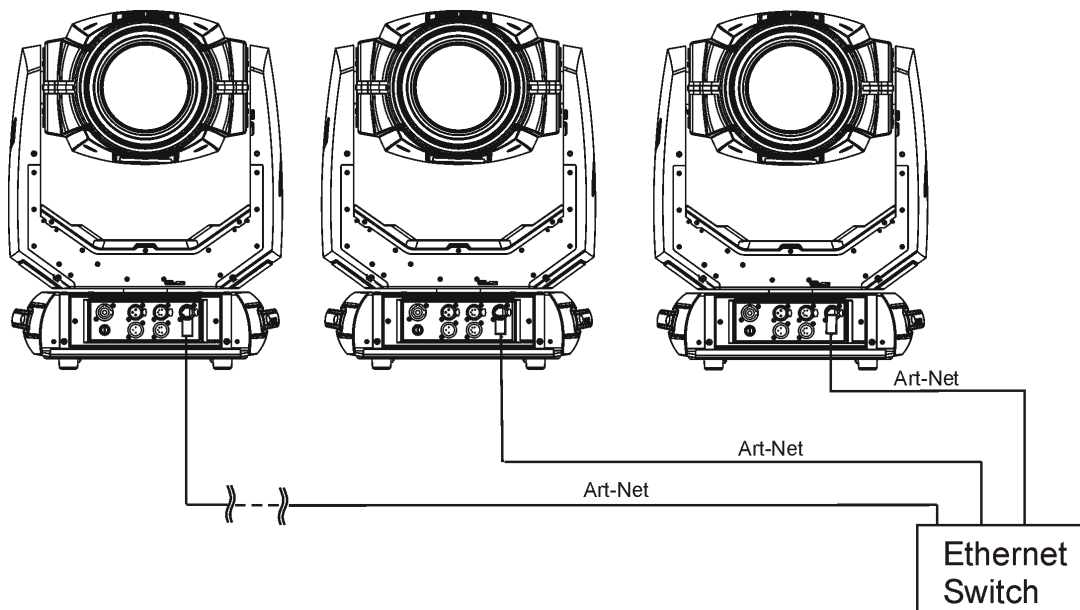

An advised PC setting: IP address: 002.xxx.xxx.xxx / 010.xxx.xxx.xxx (Different from fixture IP addresses)
NET mask: 255.0.0.0

Ethernet / DMX operation

Option "Artnet" (gMal or gMA2 or sACN) has to be selected from "Ethernet Mode" menu at first fixture.
 Option "Ethernet To DMX" has to be selected from the "Ethernet Mode" menu at the first fixture (connected to the Ethernet) in the fixture chain, next fixtures have standard DMX setting.
 Connect the Ethernet input of the first fixture in the data chain with the network. Connect the DMX output of this fixture with the input of the next fixture until all fixtures are connected to the DMX chain.

Caution: At the last fixture, the DMX chain has to be terminated with a terminator. Solder a 120 Ω resistor between Signal (-) and Signal (+) into a XLR-plug and connect it in the DMX-output of the last fixture.

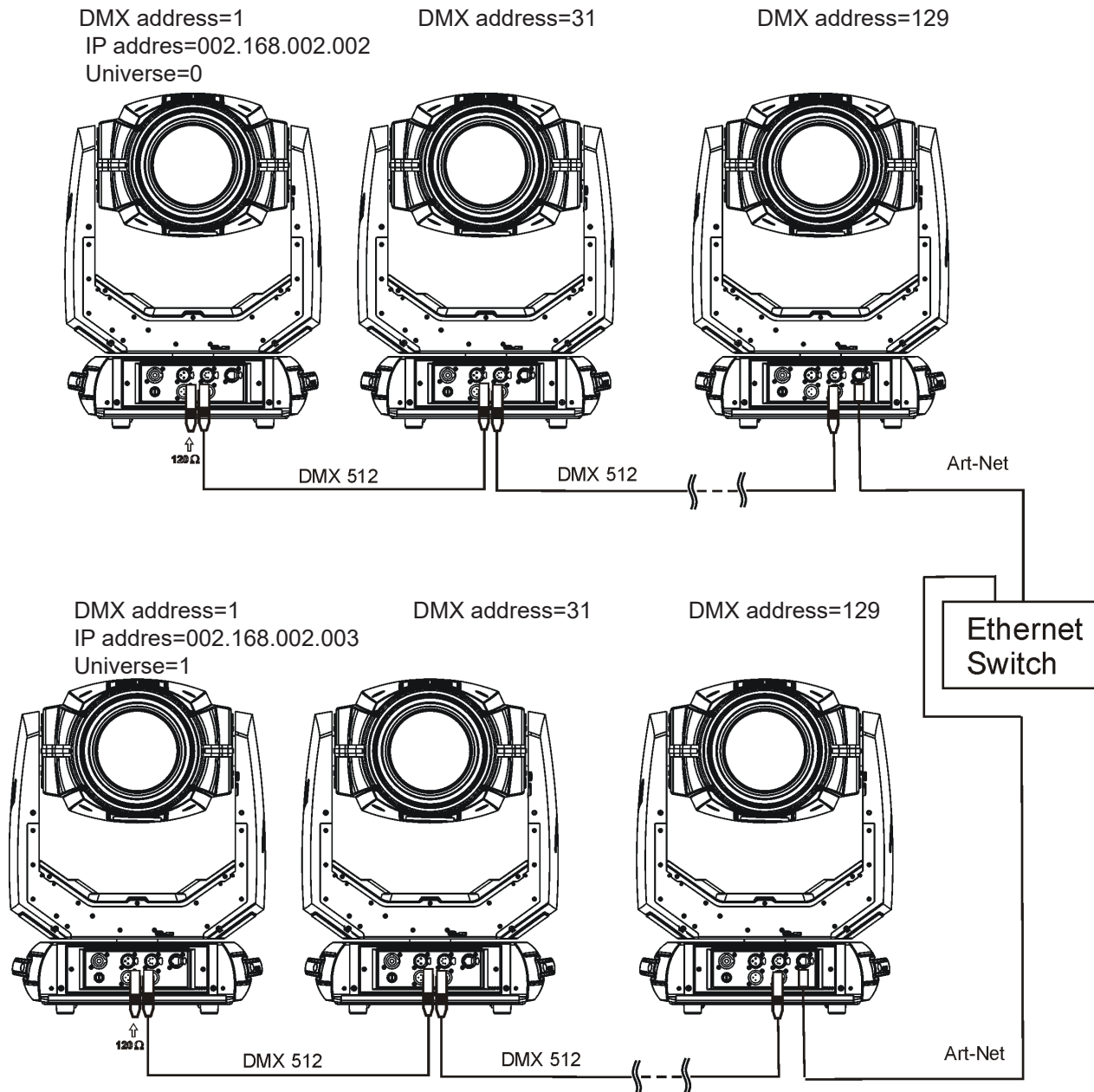

5. Remotely controllable functions

Light source

The 270W white LED light engine gives an extra punchy beam.

Colour wheel 1

This wheel contains 6 dichroic filters + open. The colour wheel can be positioned between two adjacent colours in any position. It is also possible to rotate the colour wheel continuously at different speeds ("Rainbow effect" in both directions).

Colour wheel 2

This wheel contains 6 replaceable 'SLOT&LOCK' dichroic filters + open. The colour wheel can be positioned between two adjacent colours in any position. It is also possible to rotate the colour wheel continuously at different speeds ("Rainbow effect" in both directions).

Static gobo wheel

The static gobo wheel includes 9 metal gobos. Gobo positioning and a gobo-shake function is available.

Rotating gobo wheel

The rotating gobo wheel includes 7 gobos rotating in both directions, indexable, replaceable "SLOT&LOCK" glass gobos + open position. Gobo positioning and gobo selection speed is available as well as a gobo-shake function.

Prism

The 3-facet prism rotates in both directions at different speeds, 16 prism/gobo macros are available.

Frost

Replaceable frost module provides variable frost for fine frosting.

Iris

Motorized adjustable iris, wide range of variable pulse effects.

Zoom

Motorized zoom unit enables zoom between 8° and 40° beam angle.

Dimmer/Shutter unit

Smooth 0 - 100 % dimming is provided by the electronic control unit. This unit is also used for strobe effects with variable speed.

Pan/Tilt

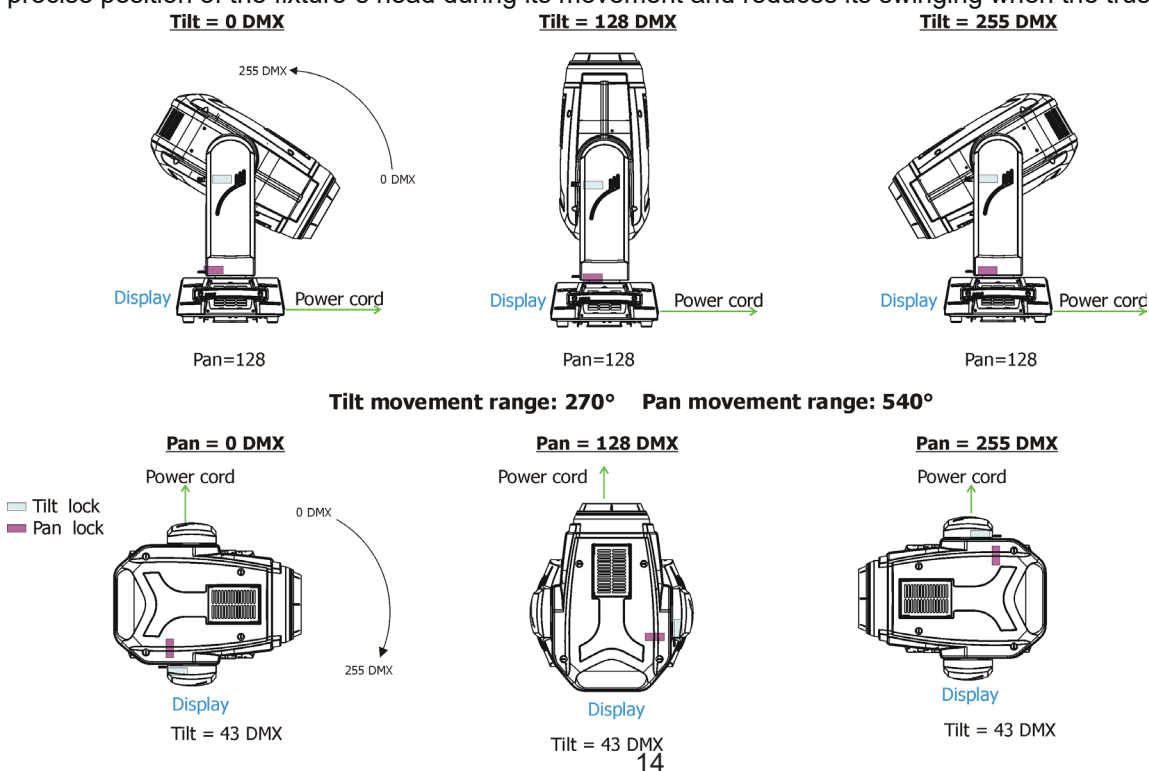

Fast pan/tilt movement due to built-in electronic motion stabilizer. The electronic motion stabilizer ensures precise position of the fixture's head during its movement and reduces its swinging when the truss shakes.





6. Control menu map

Default settings=**Bold print**

Tab	Level 1	Level 2	Level 3	Level 4	Level 5	Level 6
Addressing	DMX Address	001-255				
	DMX Presets	Mode 1				
		Mode 2				
		View Selected Preset				
	Ethernet Settings	Ethernet Mode	Disable			
			ArtNet			
			gMA1			
			gMA2			
			sACN			
		Ethernet To DMX	Off , On			
		IP Address/Net Mask	Default IP Address			
			Custom IP Address			
			Net Mask			
		ArtNet Universe	0-255			
		MANet settings	MANet/II Universe	01-256		
			MANet Session ID	01-32		
		sACN Settings	sACN Universe	00001-32000		
			sACN Priority	0-255		
Information	Fixture Times	Power On Time	Total Hours			
			Resetable Hours			
		LEDs On Time	Total Hours			
			Resetable Hours			
		Air Filters	Elapsed Time			
			Alert Period			
	Fixture Temperatures	LEDs Temperature	Current			
			Maximum NonRes.			
			Maximum Res.			
		Ambient Temperature	Current			
			Maximum NonRes.			
			Maximum Res.			
		Base Temperature	Current			
			Maximum NonRes.			
			Maximum Res.			
	DMX Values	Pan				
		:				
		Dimmer Fine				
	Wireless State	Signal Quality				
		Unlink Wireless Adapter				
	Power Channel state					
	Software Versions	Display System				
		Module M				
		Module D				
		Module G				
		Module O				
	Product IDs	Mac Address				
		RDM UID				
		RDM Label				
	View Logs	Fixture Errors				

Tab	Level 1	Level 2	Level 3	Level 4	Level 5	Level 6
		Fixture States	Power On			
			Power Off			
		Fixture Position				
		Fixture Temperatures	LED Temperatures			
			Ambient Temperatures			
			Base Temperatures			
Personality	User Mode	User A Settings				
		User B Settings				
	DMX Presets	Mode 1				
		Mode 2				
		View Selected Preset				
	DMX Input	Wired input				
		Wireless input				
		Wireless In/XLR Out				
	Pan/Tilt Settings	Pan Reverse	Off, On			
		Tilt Reverse	Off, On			
		Pan/Tilt Feedback	Off, On			
		Pan/Tilt mode	Time			
			Speed			
	Pan/Tilt EMS	On, Off				
	Microphone Sensitivity	1-10-20				
	Blackout Settings	Blackout During M.C.	Off, On			
		Blackout while:	Pan/Tilt moving	Off, On		
			Colour Wheel Moving	Off, On		
			Gobo Wheels Moving	Off, On		
	Init Effect Positions	Pan	0-255			
		:				
		Dimmer Fine	0-255			
	Screen Settings	Display Intensity	1-10			
		Screen Saver Delay	Off-10min.			
		Touchscreen Lock	Off-10min.			
		Recalibrate Touchscreen				
		Display Orientation	Normal			
			Inverted			
			Auto			
	Temperature Unit	°C, °F				
	Fan Mode	Auto				
		High				
		Quiet				
	Dimmer Curve	Linear				
		Square law				
	Date & Time Settings					
	Default Settings					
	Password Protection	Off, On				
Manual Control	Reset Functions	Total System Reset				
		Pan, Tilt reset				
		Colour System Reset				
		Iris, Gobo System Reset				
		Optics/Prism/Frost Res.				
		Iris Reset				
	Manual Effect Control	Pan	0-255			

Tab	Level 1	Level 2	Level 3	Level 4	Level 5	Level 6
		:				
		Dimmer Fine	0-255			
Stand -Alone	Test Sequences	Dynamic Mode				
		Static Mode	Pan	0-255		
			Tilt	0-255		
			Zoom	0-255		
			Focus	0-255		
	MusicTrigger	Off, On				
	Preset Playback	None				
		Test				
		Prg. 1				
		Prg. 2				
		Prg. 3				
	Play Program	Play Program 1				
		Play Program 2				
		Play Program 3				
	Edit Program	Edit Program 1	Start Step	1-100		
			End Step	1-100		
			Edit Program Steps	Step 1	Pan	0-255
				:	:	
				:	Dimmer Fine	0-255
				:	Step Time	0-25,5 sec.
				Step 100	Pan	0-255
					:	
					Dimmer Fine	0-255
					Step Time	0-25,5 sec.
Service	Adjust DMX Values	Pan	0-255			
		:				
		Dimmer Fine	0-255			
	Calibrations	Calibrate Effects	Pan	0-255		
			:			
			Iris	0-255		
		Load Default Calibrations				
	Update Software					

7. Control menu

The Robin Viva is equipped with the QVGA Robe touch screen with battery backup which allows to set the fixture's behaviour according to your needs, obtain information on its operation, test its various parts and lastly program it, if it has to be used in a stand-alone mode.

The fixture's menu can be controlled either by the control buttons or directly by touching the icon.

Control buttons on the front panel:

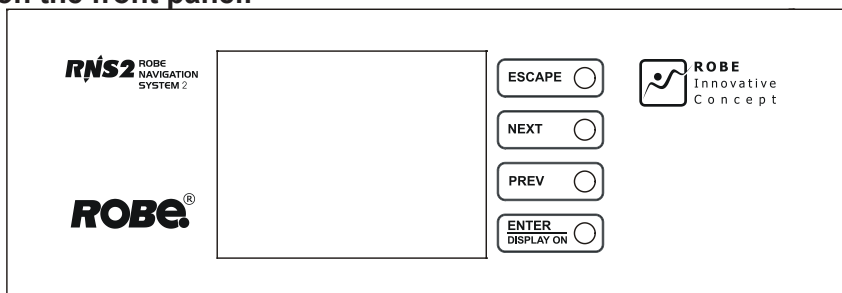

[ESCAPE] button used to leave the menu without saving changes.

[NEXT] , [PREV] buttons for moving between menu items and symbols, adjusting values.

[ENTER/Display On] button used to enter the selected menu (menu item) and to confirm adjusted value.

If the fixture is disconnected from mains, the button switches the touch screen on.

Icons used in the touch screen menu:

- [back arrow] used to move back to the previous screen (menu).
- [up arrow] used to move up on the previous page.
- [down arrow] used to move down on the next page.
- [confirm] used to save adjusted values, to leave menu or to perform desired action.
- [cancel] used to leave menu item without saving changes.
- [confirm+copy] used to save adjusted values and copy them to the next prog. step.
- [warning icon] used to indicate some error which has occurred in the fixture.
- [Ethernet] used to indicate Ethernet connected.
- [menu rotation] used to rotate menu 180 degrees from current orientation.
- [slider control] used to recall slider system for setting desired value.
- [keyboard control] used to recall keyboard system for setting desired value.
- [air filters cleaning] used to signal that cleaning period of the air filters elapsed.

The menu page displays icons for each function that you can perform from the touch screen.

After switching the fixture on, the touch screen shows the screen with the ROBE logo:

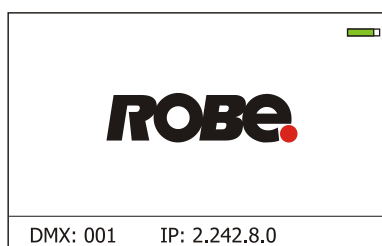

The green icon at the top right corner of the screen indicates the level of the display battery charging. If the whole icon is green, the battery is fully charged while the red icon indicates exhausted battery. The battery charges during fixture operation.

Touch any part of the screen or press the [ENTER/Display On] button to display the initial screen with the current stored DMX address:

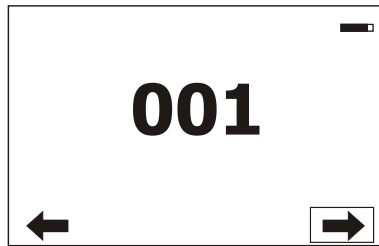

Touch the green arrow at the bottom right corner of the screen or press the [ENTER/Display On] button to enter the "Address" menu.

An item (such as a Tab, menu item, text box, icon) may be selected from a screen by simply touching the item in the list or by pressing the [NEXT] or [PREV] buttons to scroll through list items. With each press, the next item is highlighted. Press [ENTER/Display On] to select the highlighted item.

Before first fixture operation, set current date and time in the menu "Date & Time Settings" (menu path: Personality--> Date & Time Settings).

Note: The green icon at the top right corner of the screen indicates the level of the display battery charging. If the whole icon is green, the battery is fully charged while the red icon indicates exhausted battery. The battery charges during fixture operation, its charging lasts cca 6 hours.

We recommend that the fixture should be in operation at least 7 hours per week to keep the battery fully charged. If you switch the fixture on and this screen will not appear till 1 minute, switch the fixture off and on again. If the screen lights, the battery is exhausted. In case the screen still does not light, the battery is faulty.

This is also indicated by an error message "Faulty battery" and if such an error message appears the battery should be replaced immediately. The lifetime of the battery is highly dependent on ambient temperature (and consequently on base temperature). If the maximum ambient temperatures (as recorded and displayed in menu: Information -> Fixture Temperatures -> Ambient Temperature -> Maximum NonRes.) are kept within the specified limits, the battery should last for at least two years. Should the ambient temperatures exceed the specified maximum temperature, the lifetime of the batteries could be considerably shortened even up to just one year or less and also result in physical damage (battery leakage) or unreliable fixture functions.

Damage caused by batteries failed due to exceeded maximum ambient temperature cannot be claimed under warranty terms.

7.1 Tab "Address"



DMX Address - Select the menu to set the DMX start address.

DMX Preset - Use the menu to select desired channel mode.

Mode 1 - 30 control channels

Mode 2 - 23 control channels

View Selected Preset - Use the menu to display channels included in the selected mode.

Ethernet Settings - The menu allows all needed settings for the Ethernet operation

Ethernet Mode

Disable - The option disables Ethernet operation.

Artnet - Fixture receives Artnet protocol

gMAI - Fixture receives MANet 1 protocol

gMA2 - Fixture receives MANet 2 protocol

sACN - Fixture receives sACN protocol

Ethernet To DMX - Fixture receives protocol from the Ethernet input and sends DMX data to its DMX output (fixture works as an "Ethernet/DMX converter", next fixture can be connected to its DMX output and you can build a standard DMX chain by connecting another fixtures.

Only one fixture has to be connected to the Ethernet.

IP Address/Net Mask - Select this menu to set IP address. IP address is the Internet protocol address. The IP uniquely identifies any node (fixture) on a network.

There cannot be 2 fixtures with the same IP address on the network!

Default IP Address - Preset IP address, you can set up only first byte of IP address (2 or 10) e.g. **002.019.052.086**.

Custom IP Address - The option enables to set up all bytes of IP address.

Net Mask - The option enables to set up all bytes of Net Mask.

ArtNet Universe - Use this item to set a Universe (0-255). The Universe is a single DMX 512 frame of 512 channels.

MANet Settings - Use this menu to set parameters for MANet operation.

MANet Universe I/II - The value of this item can be set in range 1-256.

MANet Session ID - The value of this item can be set in range 1-32.

sACN Settings - Use this menu to set parameters for sACN operation.

sACN Universe - The value of this item can be set in range 1-32000.

sACN Priority - The value of this item can be set in range 0-255.

7.2 Tab "Information"



Fixture Times - The menu provides readouts of fixture and LED module operation hours.

Power On Time Hours - Select this menu to read the number of fixture operation hours.

Total Hours - The item shows the total number of the operation hours since the Robin Viva has been fabricated.

Resetable Hours - The item shows the number of the operation hours that the Robin Viva has been powered on since the counter was last reset.

In order to reset this counter to 0, touch the text box next to the item "Resetable Hours:"

LEDs On Time - Select this menu to read the number of LED source operation hours.

In order to reset some counter to 0, touch the yellow text box next to desired colour.

Air Filters - Regular cleaning of the air filters is very important for the fixture's life and performance. Build-up of dust, dirt and fog fluid residues reduces the fixture's light output and cooling ability.

The two items of this menu help you to keep cleaning period of the air filters.

Alert period - Cleaning schedule for the fixture depends on the operating environment.

It is therefore impossible to specify accurate cleaning interval. This item allows you to change the cleaning interval of the air filters. This "alert" value is 300 hours and it is set as default. Inspect the fixture within its 300 hours of operation to see whether cleaning is necessary. If cleaning is required, clean all air filters and change the value in this menu on acceptable level. Min. level of alert period is 10 hours, max. is 300 hours.

Elapsed Time - The item allows you to read the time which remains to cleaning air filters.

The time period is set in the menu mentioned above.

Expired time period is signalled by a negative mark (-) at the time value and a warning icon on the display.

Clean the filters and reset this menu item (by touching the text box next to the item "Elapsed Time").

Fixture Temperatures - The menu is used to view temperatures of the fixture's inside.

LEDs temperatures - The menu shows temperature on the LED source.

Cur. - A current temperature of the LED source.

Max. - A maximum temperature of the LED source since the fixture has been fabricated.

Max. Res. - A maximum temperature of the LED source since the counter was last reset.

In order to reset some counter to 0, touch desired text box under item "Max.Res."

Ambient Temperature - The menu shows temperature of the induced air on the fan in the fixture base .

Current - A current temperature of the induced air in the fixture base.

Maximum NonRes. - A maximum temperature of the induced air in the fixture base since the fixture has been fabricated.

Maximum Res. - A maximum temperature of the induced air in the fixture base since since the counter was last reset.

In order to reset this counter to 0, touch the text box next to the item "Maximum Res."

Base Temperature - The menu shows temperature in the fixture base (on the display PCB).

Current - A current temperature in the fixture base.

Maximum NonRes. - A maximum temperature in the fixture base since the fixture has been fabricated.

Maximum Res. - A maximum temperature in the fixture base since the counter was last reset.

In order to reset this counter to 0, touch the text box next to the item "Maximum Res."

DMX Values - The menu is used to read DMX values of each channel received by the fixture.

Wireless State - The menu serves for reading of the wireless operation status

Unlink Wireless Adapter - The menu item allows unlinking the fixture from the transmitter .

Power Channel State - The menu item shows state of the Power/Special functions switches.

Software Version - Select this item to read the software version of the fixture modules:

Display System - A display processor on the display board in the fixture base

Module M - A pan/Tilt processor.

Module D - Colours/light source control processor.

Module G - A rot. gobo/stat. gobo/iris processor.

Module O - A focus/zoom/prism/frost/ processor .

Product IDs - The menu is used to read the MAC Address ,RDM UID and RDM Label.

View Logs - Use this menu to read fixture's data which have been recorded during fixture operation. This collected data allows easier troubleshooting.

Fixture Errors - Use this menu to read fixture errors which have occurred during fixture operation.

Fixture States - Recorded following actions: Fixture On, Fixture Off.

Fixture Position - Recorded installation positions of the fixture:

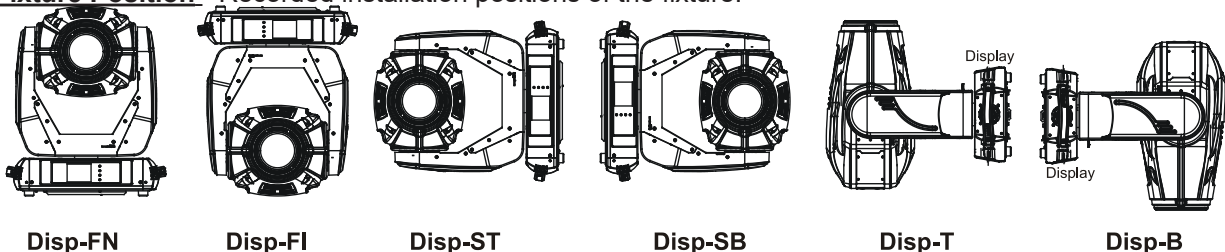

Fixture Temperatures - Recorded temperatures which have exceeded defined levels.

Note: The log buffer can contain 8000 records max. If the buffer is full, old data will be overwritten.

7.3 Tab "Personality"



User mode - The Robin Viva allows you to recall 2 user settings. After switching the fixture on for the first time, the User A settings is active. Now all changes made in the "Personality" menu , "Addressing" menu and the "Music Trigger" and "Preset Playback" items from the "Stand-alone" menu are saved to the User A settings. If you now select the User B settings, from this moment the changes made in these menus will be saved to the

User B settings. After switching the fixture off and on, the User B setting is active. In this way you may use the two fixture operating behaviours.

User A Settings - the function recalls the user A settings.

User B Settings - the function recalls the user B settings.

DMX Preset - Use the menu to select desired channel mode.

Mode 1 - 30 control channels

Mode 2 - 23 control channels

View Selected Preset - Use the menu to display channels included in the selected mode.

DMX Input- Use the menu to select mode of receiving DMX signal.

Wired - DMX signal is received by means of the standard DMX cable.

Wireless - DMX signal is received by means of the inbuilt wireless module.

Wireless In/XLR Out- the fixture receives wireless DMX and sends the signal to its wired DMX output.

The fixture behaves as " Wireless/Wired" adapter.

The options "Wired" and "Wireless" are also stated in DMX chart (channel Power/Special functions).

Pan/Tilt Settings - Use the menu set behaviour of both pan and tilt movements.

Pan Reverse - The item allows to invert pan movement.

Tilt Reverse - The item allows to invert tilt movement.

Pan/Tilt Feedback - The item allows to return the moving head to the required pan/tilt position after changing the position by an external force if this option is set on.

Note. Be careful, the Pan/Tilt Feedback should be permanent On, the option Off is not suitable for standard operation and the head can be damaged!

Pan/Tilt mode - Use this menu to set the mode of the pan/tilt movement

Time mode – The pan and tilt will move with different speeds and they will come at the same time to the end point of their tracks (pan and tilt use their optimal speeds).

Time of the pan/tilt movement (25.5 sec. max.) is set by the channel "Pan/Tilt speed, Pan/Tilt time".

Speed Mode - Both pan and tilt will move with the same speed as adjusted at the channel "Pan/Tilt speed, Pan/Tilt time".

Pan/Tilt EMS - Built-in electronic motion stabilizer ensures precise position of the fixture's head during its movement and also reducing its swinging when the truss shakes.

Microphone Sensitivity - Enter the menu if you want to adjust the microphone sensitivity from 1 (max.) to 20 (min.).

Blackout Settings - Use the menu if you need to close the light output under certain conditions which are described below

Blackout DMC - Blackout during movement correction. Set this option On if you wish to close light output during the time when the head goes to its correct position, which has been changed by an external force.

Active Blackouts - Use this menu if you wish to close the light output during effect changes.

Pan/Tilt Moving - The menu item enables to close light output while the pan/tilt coordinates are changing.

Colour Wheels Moving - The menu item enables to close light output while the colour wheel 1 (2) is moving.

Gobo Wheel Moving - The menu item enables to close light output while the rot. gobo wheel I is moving.

Init Effect Positions - Use the menu to set all effects to the desired positions at which they will stay after switching the fixture on without DMX signal connected.

Screen Settings - Use this menu to change the touch screen settings.

Display Intensity - The item allows to control the intensity of the screen (1-min., 10-max.).

Screen saver Delay - The item allows you to keep the screen on or to turn it off automatically after 1-10 minutes after last touch (or pressing any button on the control panel).

Touchscreen Lock - The item allows you to lock the screen after last touch (or pressing any button on the control panel). The time delay can be set in range of 1-10 minutes. To unlock the screen, press the [ENTER/Display On] button.

Recalibrate Touchscreen - The item starts calibration of the touchscreen. Follow the instructions on the screen.

Display Orientation - The menu allows to change display orientation.

Normal - Standard display orientation if the fixture is placed horizontally (e.g. on the ground).

Inverted - Inverted orientation (needed if the fixture is hanging on the truss).

Auto - The option activates a gravitation sensor for automatic screen orientation.

Note: **Auto** option is set as default. You change the display orientation by touching the icon  on the display, and the option set in the "Display Orientation" menu is temporarily overridden.

Dimmer Curve - You can select desired dimmer curve: Linear or Square Law.

Temperature unit - Use the menu item to change temperature unit from °C to °F.

Fan Mode - Use the menu to set the fixture fans to max. fan power mode ("**High**") or to the auto-control mode ("**Auto**"). The third mode ("**Quiet**") allows to set desired noise of the fans and the adjusted noise level is kept during fixture operation. The "**Fan Noise Level**" menu serves for adjusting fans power from min. to max. To switch the fixture to the "Quiet" mode can be also realized by DMX value from range of 241-255 on the "power/Special functions" channel.

Note: the light output at min. level of the fan noise is reduced.

Date & Time Settings - Use this menu to set current date and time for the fixture log system (menu "**View Logs**"). Set this menu item before first fixture operation.

Default Settings - The menu item allows to set all fixture parameters to the default (factory) values.

Password Protection - if the item is on, a password is required to enter the fixture menu. The password cannot be changed. The password prevents unauthorized person from changing setting of the fixture.

7.4 Tab "Manual Control"



Reset Functions - The menu allows to reset the fixture either per function modules or all modules together.

Total System Reset - The item resets all function modules.

Pan, Tilt Reset - The item resets a pan and tilt movement.

Colour System Reset - The item resets a colour wheel and CMY/CTO flags.

Iris, Gobo System Reset - The item resets a static/rotating gobo wheel.

Optics/Prism/Frost Res. - The item resets a zoom, focus, prism and a frost module.

Manual Effect control - Use the menu to control all fixture channels by means of the control panel.

7.5 Tab "Stand-alone"



Test Sequences - Use the menu to run a test/demo sequences without an external controller, which will show you some possibilities of using Robin Viva.

Dynamic Mode - This mode uses all Robin Viva functions including pan/tilt movement and therefore is good for a complete introduction of the fixture.

Static Mode - This mode is suitable for projections on the wall, ceiling or ground without any pan/tilt movement. Adjust the pan, tilt, zoom, focus and hot-spot to desired positions and start test sequences by touching the green ► icon.

Music Trigger - Use the item to activate the sound control of the running program via the built-in microphone.

Preset Playback - This menu allows you to select the program which will be played in a loop after switching the fixture on (the option is commonly used in a stand-alone operation without an external controller).

None - The option disables "Presetting playback" function.

Test - The option starts the test sequences.

Prog. 1 - The option starts user program No. 1.

Prog. 2 - The option starts user program No. 2.

Prog. 3 - The option starts user program No. 3.

Play program - Use the menu to run desired program in a loop.

Play Program 1 - The option starts user program No.1.

Play Program 2 - The option starts user program No. 2.

Play Program 3 - The option starts user program No. 3.

Edit Program - Use the menu to create or to edit desired program. The Robin Viva offers 3 free programs, each up to 100 steps.

Edit Program 1 - The option allows to edit user program No.1.





Edit Program 2 - The option allows to edit user program No.2.

Edit Program 3 - The option allows to edit user program No.3

To edit program:

1. Touch the item which you want to edit ("Edit Program 1" - "Edit Program 3").
2. Touch the item "Edit Program Steps".
3. Touch the item "Step 1".
4. From the list of effects touch desired effect and set its value. Browse through the list by touching the [up arrow] and [down arrow] and set all desired effects.
An item "Step Time" (value of 0-25.5 sec.) is the time during which effects last in the current step
5. Save adjusted effects to the current step by touching the [confirm] or save and copy them to the following step by touching the [confirm+copy]. By touching the text box "Preview" next to the current program step you can view created scene.
6. Repeat the steps 4 and 5 for next program steps.
7. After editing desired program steps, adjust the length of the program by touching the text boxes "Start Step" and "End Step".

Meaning of the icons used in the "Edit Program" menu:

-  - moves down on the next page
-  - moves up on the previous page
-  - saves adjusted values and leaves menu
-  - saves values to the current step and copy them to the following prog. step
-  - leaves menu without saving values

There is a chart describing behaviour of items "Pan/Tilt Macro" and "P./T. Macro Speed".

DMX	Pan/Tilt Macro
0 - 9	Disabled pan/tilt macro
10 - 31	Reserved
32 - 63	Figure of circle (from small to large)
64 - 95	Figure of horizontal eight (from small to large)
96 - 127	Figure of vertical eight (from small to large)
128 - 159	Figure of rectangle (from small to large)
160 - 191	Figure of triangle (from small to large)
192 - 223	Figure of star (from small to large)
224 - 255	Figure of cross (from small to large)
	Pan/Tilt Macro Speed
0	No macro generation Macro generation from fast to slow-forwards No macro generation Macro generation from slow to fast-backwards

7.6 Tab "Service"



Adjust DMX Values - The menu allows you to set all effects to desired positions before fine calibration of the effects .

Calibrations - This menu enables fine calibration of fixture effects and download default calibration values.

Calibrate Effects - The menu allows the fine adjustment of effects. The menu contains list of effects which can be calibrated:

Pan- a fine pan movement
Tilt - a fine tilt movement
Colour Wheel 1 - a colour wheel 1
Colour wheel 2 - a colour wheel 2
Static Gobo - a static gobo wheel movement
Rot. Gobo Wheel - a carousel of rotating gobos
R. Gobo Index 1 - a fine movement of rotating gobo 1
R. Gobo Index 2 - a fine movement of rotating gobo 2
R. Gobo Index 3 - a fine movement of rotating gobo 3
R. Gobo Index 4 - a fine movement of rotating gobo 4
R. Gobo Index 5 - a fine movement of rotating gobo 5
R. Gobo Index 6 - a fine movement of rotating gobo 6
R. Gobo Index 7 - a fine movement of rotating gobo 7
Prism - a prism movement
Prism Rot - a prism rotation
Zoom - a zoom module
Frost 1/1 - a frost position 1
Frost 1/2 - a frost position 2
Focus - a focus module
Iris - an iris module

By using these items you can calibrate and adjust effects to their right positions.

Calibration via the control board

1. Disconnect DMX controller from the fixture and enter the "Calibrate Effects" menu.
2. Use the [up arrow] and [down arrow] to find desired effect and touch it to enter the fine effect adjustment screen.
3. Set desired value and save it by touching the [confirm].
4. Repeat steps 2 and 3 for the next effects.
5. After calibrating all effects, touch the [confirm] to save all adjusted values and reset the fixture.

Calibration via the DMX controller

1. Connect DMX controller to the fixture and set fixture effects to the desired positions before fine calibration.
2. Enter the "Calibrate Effects" menu and now you can exactly calibrate desired effects by DMX controller.

There is a calibration protocol:

Effect	Mode 1	Mode 2
Pan	channel 31	channel 24
Tilt	channel 32	channel 25
Colour wheel 1	channel 33	channel 26
Colour wheel 2	channel 34	channel 27
Static Gobo	channel 35	channel 28
Rot. Gobo Wheel	channel 36	channel 29
R. Gobo Index 1	channel 37	channel 30
R. Gobo Index 2	channel 38	channel 31
R. Gobo Index 3	channel 39	channel 32
R. Gobo Index 4	channel 40	channel 33
R. Gobo Index 5	channel 41	channel 34
R. Gobo Index 6	channel 42	channel 35
R. Gobo Index 7	channel 43	channel 36
Prism	channel 44	channel 37
Prism rot.	channel 45	channel 38
Zoom	channel 46	channel 39
Frost 1/1	channel 47	channel 40
Frost 1/2	channel 48	channel 41
Focus	channel 49	channel 42
Iris	channel 50	channel 43

After having calibrated all effects, touch the [confirm] to save adjusted values and reset the fixture.

Load Default Calibrations - The item loads default (factory) calibration values.

Calibrate Pan/Tilt EMS - This menu item allows calibration of the pan/tilt electronic motion stabilizer. Important: during this calibration any external force must not influence the fixture and the surface at which the fixture stands (or truss if the fixture hangs) has to be without movement, shake, strokes etc.

Updating software - The menu item allows you to update software in the fixture via either serial or USB port of PC.

The following are required in order to update software:

- PC running Windows 95/98/2000/XP/7/8 or Linux
- DMX Software Uploader
- Flash cable RS232/DMX No.13050624 (if you want to use a serial port of PC)
- Robe Universal Interface (if you want to use an USB port of PC)

Note: Software update should execute a qualified person. If you lack qualification, do not attempt the update yourself and ask for help your ROBE distributor.

DMX address, IP address, programs 1-3 and all items in the menu "Personality" will be set to their default (factory) values.

To update software in the fixture:

I. Installation of the DMX Software Uploader.

1. DMX Software Uploader program is available from the ROBE web site at WWW.robe.cz.
2. Make a new directory (e.g. Robe_Uploader) on your hard disk and download the software to it.
3. Unpack the software.

II. Fixture software updating.

1. Determine which of your ports is available on your PC and connect it:
 - with the DMX input of the fixture if you using the flash cable RS232/DMX
 - with the DMX output of the Robe Universal Interface if you using the USB cable.

Disconnect the fixture from the other fixtures in a DMX chain. Turn both the computer and the fixture on. Make sure the lamp is switched off (only if the fixture involves a lamp).

2. Switch the fixture to the updating mode by touching the "Updating Software " item

Note: If you do not want to continue in software update, you have to switch off and on the fixture to escape from this menu.

We recommend to cancel all running programs before starting the Software Uploader.

3. Run the Software Uploader program. Select desired COM and then click on the Connect button. (Select COM if the serial port is used or Robe Universal Interface if the USB port is used).

If the connection is OK, click on the "Start Uploading button" to start uploading. It will take several minutes to perform software update.

If the option "Incremental Update" is not checked, all processors will be updated (including processors with the same software version).

If you wish to update only later versions of processors, check the "Incremental Update box".

Avoid interrupting the process. Update status is being displayed in the Info Box window.

When the update is finished, the line with the text "The fixture is successfully updated" will appear in this window and the fixture will reset with the new software.

Note: In the case of an interruption of the upload process (e.g. power cut), the fixture keeps the updating mode and you have to repeat the software update again.

8. RDM

This fixture supports RDM operation. RDM (Remote Device Management) is a bi-directional communications protocol for use in DMX512 control systems, it is the new open standard for DMX512 device configuration and status monitoring.

The RDM protocol allows data packets to be inserted into a DMX512 data stream without adversely affecting existing non-RDM equipment. By using a special „Start Code,“ and by complying with the timing specifications for DMX512, the RDM protocol allows a console or dedicated RDM controller to send commands to and receive messages from specific moving lights.

RDM allows explicit commands to be sent to a device and responses to be received from it.

The list of commands for Robin Viva is the following.

Parameter ID	Discovery command	SET command	GET command
DISC_UNIQUE_BRANCH	*		
DISC_MUTE	*		
DISC_UN_MUTE	*		
DEVICE_INFO			*
SUPPORTED_PARAMETERS			*
SOFTWARE_VERSION_LABEL			*
DMX_START_ADDRESS		*	*
IDENTIFY_DEVICE		*	*

DEVICE_MODEL_DESCRIPTION			*
MANUFACTURER_LABEL			*
DEVICE_LABEL		*	*
SENSOR_DEFINITION			*
SENSOR_VALUE			*
DISPLAY_INVERT		*	*
DISPLAY_LEVEL		*	*
PAN_INVERT		*	*
TILT_INVERT		*	*
DEVICE_RESET		*	
DMX_PERSONALITY		*	*
DMX_PERSONALITY_DESCRIPTION			*
STATUS_MESSAGES			*
STATUS_ID_DESCRIPTION			*
DEVICE_HOURS ¹			*

¹...Commands relative resetable values

9. Wireless DMX operation

The wireless DMX version of the Robin Viva is equipped with the Lumen Radio CRMX module and antenna for receiving DMX signal. CRMX module operates on the 2.4 GHz band.

The item " Wireless " from the menu "DMX Input" allows you to activate receiving of wireless DMX (Personality--> DMX Input -->Wireless.).

To link the fixture with DMX transmitter.

The fixture can be only linked with the transmitter by running the link procedure at DMX transmitter . After linking , the level of DMX signal (0-100 %) is displayed in the menu item "Wireless State" (Information -->Wireless State).

To unlink the fixture from DMX transmitter.

The fixture can be unlinked from receiver via the menu item " Unlink Wireless Adapter" (Information--> Wireless State --> Unlink Wireless Adapter.).

10. Error and information messages

Information icon



- Air Filters Cleaning

This icon signals that cleaning period of the air filters has elapsed and you have to clear air filters and reset the menu item "Elapsed Time".

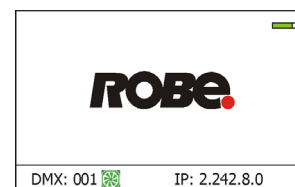

Errors

Error in the fixture is signalled by the yellow warning icon at the bottom line of the screen:

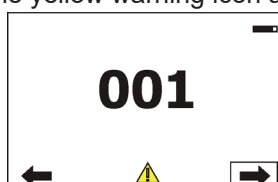

Touch the warning icon or press the [ESCAPE] button to display error messages.
List of error and information messages:

Tilt Error 1 (Tilt Error 2)

This message will appear after the reset of the fixture if the head's magnetic-indexing circuit malfunctions (sensor failed or magnet is missing) or the stepping motor is defective or its driving IC on the PCB. The head is not located in the default position after the reset.

Pan Error 1 (Pan Error 2)

This message will appear after the reset of the fixture if the yoke's magnetic-indexing circuit malfunctions (sensor failed or magnet is missing) or the stepping motor is defective or its driving IC on the PCB. The yoke is not located in the default position after the reset of the fixture.

Colour Wheel 1 Error 1 (Colour Wheel 1 Error 2)

The messages will appear after the reset of the colour wheel 1 if this wheel is not located in the default position.

Colour Wheel 2 Error 1 (Colour Wheel 2 Error 2)

The messages will appear after the reset of the colour wheel 1 if this wheel is not located in the default position.

Prism Error 1 (Prism Error 2)

The messages will appear after the reset of the prism wheel if this wheel is not located in the default position.

Zoom Error 1 (Zoom Error 2)

The messages will appear after the reset of the zoom module if the zoom lens is not located in the default position.

Focus Error 1 (Focus Error 2)

The messages will appear after the reset of the focus module if the focus lens is not located in the default.

Gobo Carousel Error 1 (Gobo Carousel Error 2)

The messages will appear after the reset of the rotating gobo wheel if this wheel is not located in the default position.

Gobo rotation Error 1 (Gobo Rotation Error 2)

The messages will appear after the reset of the rotating gobo wheel if the rotating gobos are not located in the default positions.

Static Gobo Error 1 (Static Gobo Wheel Error 2)

The messages will appear after the reset of the static gobo wheel if this wheel is not located in the default position.

Clean Air Filters

The message informs that the item "Elapsed Time" in the "Fixture Information" menu is at 0 value. Clean air filters and reset this counter.

White 1 Short Error (White 2 Short Error/ White 3 Short Error/ White 4 Short Error)**White 5 Short Error (White 6 Short Error/ White 7 Short Error/ White 8 Short Error)**

Some white LEDs in the light source have short circuit or are disconnected.

11. Technical Specifications

Electrical

Power supply:.....electronic auto-ranging
Input voltage range:..... 100-240V, 50/60Hz
Max. power consumption:.....400 W@230V
Fuse:.....T 4 A

Light source

270 W white engine
Colour temperature: 6500K
CRI=75

Colour wheel 1

6 dichroic filters (deep red, deep blue, yellow, magenta, green, Congo blue)

Colour wheel 2

6 replaceable 'SLOT&LOCK' dichroic filters (light green, lavender, pink, CTO, blue, orange)

Static gobo wheel

9 metal gobos, image diameter=22.5mm, aluminium, thickness=0.5 mm
Gobo wheel continuous rotation



Rotating gobo wheel

7 glass gobos can be indexed and rotated in both directions at different speeds
Gobo wheel continuous rotation
Glass gobos: outside diameter=26.8 mm, max. thickness=4 mm, high temperature borofloat or better glass

"Slot&lock" system for easy replacement of gobos

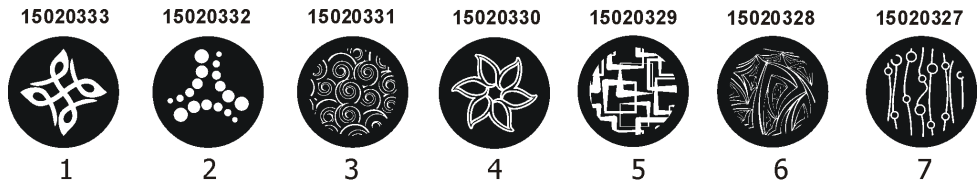

Prism

Rotating 3-facet 11° prism with continuous rotation in both directions

Iris

Motorized iris for different beam diameters

Frost filter

replaceable,variable frost filter 20°
10°and 30° filters as optional (not included)

Zoom

Linear motorized zoom (8°-40°)

Strobe

Strobe effect with variable speed (max.15 flashes/sec.)

Dimmer

Smooth dimmer from 0 - 100 %

Control

Graphic touch screen for fixture setting and addressing
Gravitation sensor for auto screen positioning
Battery backup of the touch screen
Readout fixture and light source usage, receiving DMX values, temperatures, etc
Built-in analyzer for easy fault finding, error messages
Built-in demo sequences
Quiet fans cooling,
Stand-alone operation
3 user editable programs, each up to 100 steps
Supported protocols: USITT DMX 512, RDM, ArtNet, MANet, MANet2, sACN
Support of RDM (Remote Device Management)
2 DMX modes (30, 23, control channels)

Optional Wireless DMX/RDM module

Compliance with USITT DMX-512 (1986 & 1990) and 512-A
Full DMX fidelity and frame integrity
Auto sensing of DMX frame rate and frame size
<5ms DMX latency
Operational frequency range of 2402-2480 MHz
Producer: LumenRadio

Pan/Tilt

Pan movement range 540°
Tilt movement range 270°
16 bit movement resolution
Pan/Tilt electronic motion stabilizer
Automatic Pan/Tilt position correction
Remotely controllable speed of pan/tilt movement for easy programming
Movement control: tracking and vector
Pan/tilt-lock mechanism

Rigging

Mounting points: 2 pairs of 1/4-turn locks
Mounting horizontally or vertically via 2 Omega brackets

Temperatures

Maximum ambient temperature : 45° C
Maximum housing temperature : 80° C

Minimum distances

Min. distance from flammable surfaces: 0.5 m
Min. distance to lighted object: 2 m

Total heat dissipation

1460 BTU/h (calculated)

Weight (net)

17.5 kg

Dimensions (mm)

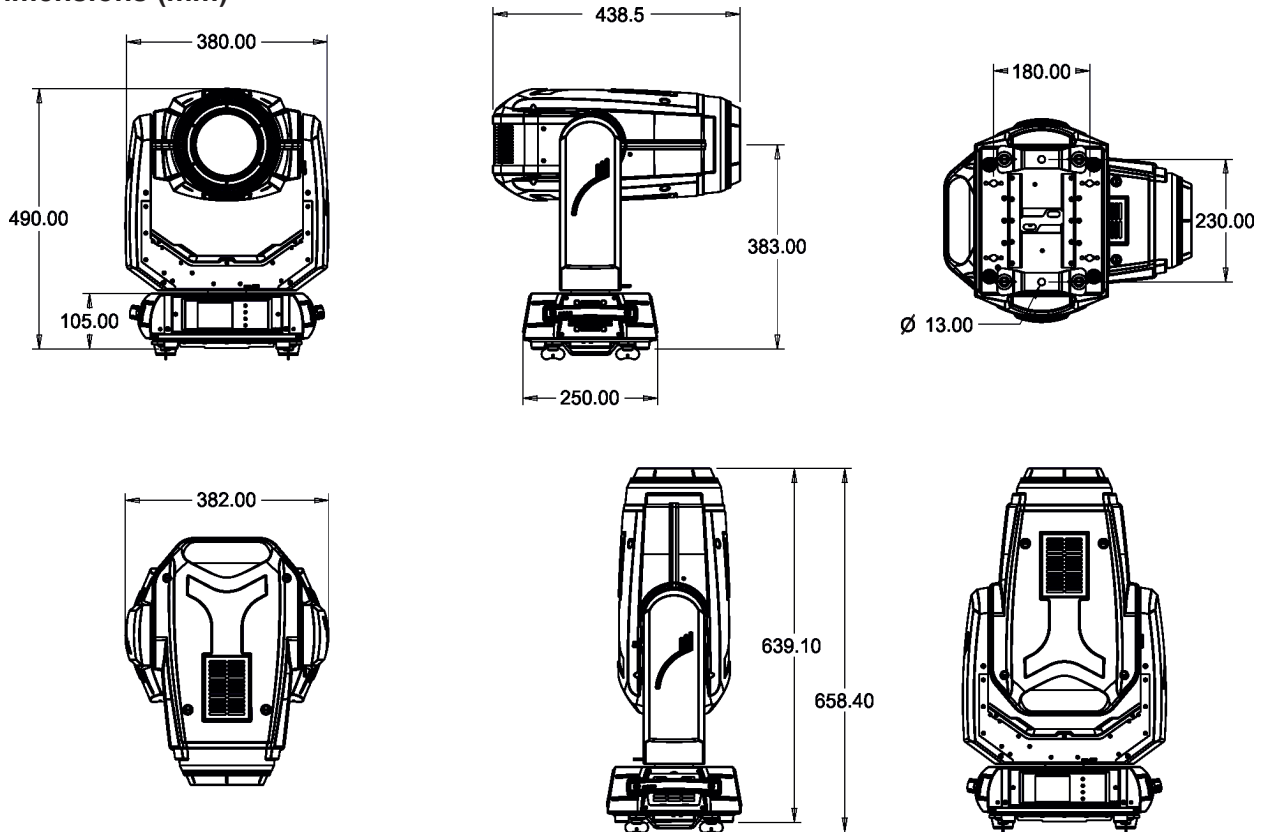

Connection

DMX data in/out: Locking 3-pin and 5-pin XLR
ArtNet: RJ 45 (Neutrik Ethercon)
AC power IN: Chassis connector Neutrik PowerCon, NAC3MPX

Accessories

1 x Omega adapter CL-regular 2 pcs in box (P/N 10980033)
1 x power cable

Optional Accessories

Frost 1° (exchange) - assembled (P/N 10980308)
Frost 10° (exchange) - assembled (P/N 10980309)
Frost 30° (exchange) - assembled (P/N 10980310)
Upgrade kit CRMX Univerzal 260 (P/N 99030100)
Doughty Trigger Clamp (P/N 17030386)
Safety wire 35 kg (P/N 99011963)

12. Maintenance and cleaning

It is absolutely essential that the fixture is kept clean and that dust, dirt and smoke-fluid residues must not build up on or within the fixture. Otherwise, the fixture's light-output will be significantly reduced. Regular cleaning will not only ensure the maximum light-output, but will also allow the fixture to function reliably throughout its life. A soft lint-free cloth moistened with any good glass cleaning fluid is recommended, under no circumstances should alcohol or solvents be used!

DANGER !
***Disconnect from the mains before starting any
maintenance work***

The front objective lens will require weekly cleaning as smoke-fluid tends to building up residues, reducing the light-output very quickly. The cooling-fans should be cleaned monthly.

The interior of the fixture should be cleaned at least annually using a vacuum-cleaner or an air-jet.

Dichroic colour filters, gobo wheels and the internal lenses should be cleaned monthly.

Remove dust and dirt from the fans and cooling vents using a soft brush and vacuum-cleaner.

**Important! Check the air filters periodically and clean before they become
clogged!**

Clean the air filters placed in the fixture bases. Use a vacuum cleaner, compressed air or you can wash them and put back dry.

After replacing the air filters, reset the elapsed time counter in the menu "Information" (Information--->Air Filters---> Elapsed Time).

Replacing the fuse.

Before replacing the fuse, unplug mains lead.

- 1) Remove the fuse holder on the rear panel of the base with a fitting screwdriver from the housing (anti-clockwise).
- 2) Remove the old fuse from the fuse holder.
- 3) Install the new fuse in the fuse holder (only the same type and rating).
- 4) Replace the fuseholder in the housing and fix it.

12.1 Disposing of the product

To preserve the environment please dispose or recycle this product at the end of its life according to the local regulations and codes.

13. Photometric diagrams

Beam angle 8° - Min. zoom

Total Output: 4945 lumens

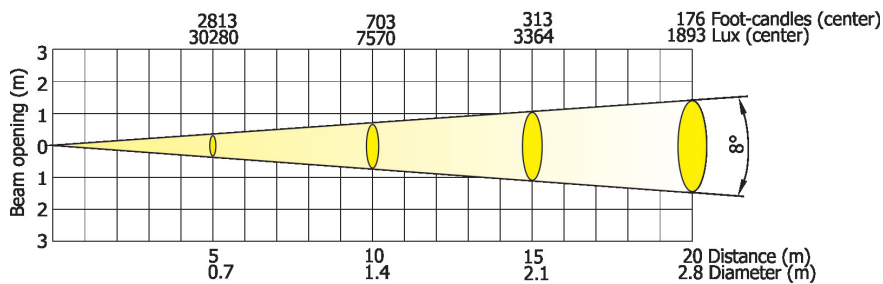

Beam angle 40° - Max. zoom

Total Output: 5790 lumens

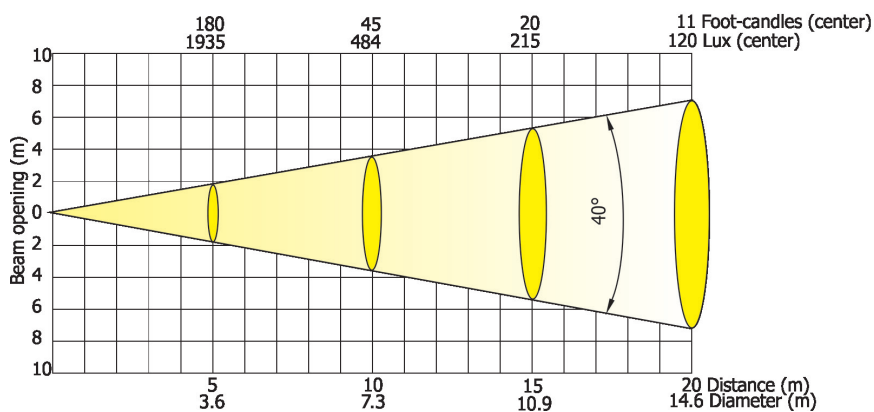

14. ChangeLog

This section summarizes all types of changes in the user manual.

Version of the manual	Date of issue	Description of changes
1.1	13/01/2016	DMX protocol ver. 1.3
1.2	11/01/2016	DMX protocol ver. 1.4
1.3	13/02/2017	DMX protocol ver. 1.5 (Quiet mode at channel 6)
1.4	17/01/2018	Optional accessories changed

January 17, 2018

Copyright © 2016-2018 Robe Lighting - All rights reserved

All Specifications subject to change without notice

Made in CZECH REPUBLIC by ROBE LIGHTING s.r.o. Palackeho 416/20 CZ 75701 Valasske Mezirici

DMX protocol

Robin Viva - DMX protocol				
Version 1.5		Mode 1 - Standard 16 bit, Mode 2 - Reduced 8 bit		
Mode/channel		DMX Value	Function	Type of control
1	2			
1	1		Pan	
		0 - 255	Pan movement by 540°	proportional
2	2		Pan Fine	
		0 - 255	Fine control of pan movement	proportional
3	3		Tilt	
		0 - 255	Tilt movement by 270°	proportional
4	4		Tilt fine	
		0 - 255	Fine control of tilt movement	proportional
5	5		Pan/Tilt speed , Pan/Tilt time	
		0	Standard mode	step
		1	Max. Speed Mode	step
			Pan/Tilt speed mode	
		2 - 255	Speed from max. to min.	proportional
			Pan/Tilt time mode	
		2 - 255	Time from 0.2 s to 25.5 sec.	proportional
6	6		Power/Special functions	
		0 - 9	Reserved	
			<i>To activate following functions, stop in DMX value for at least 3 s and shutter must be closed at least 3 sec. („Shutter,Strobe“ channel 28/22 must be at range: 0-31 DMX). Corresponding menu items are temporarily overridden except DMX Input.</i>	
		10-14	DMX input: Wired DMX *	step
		15-19	DMX input: Wireless DMX *	step
			* function is active only 10 seconds after switching the fixture on	
		20-24	Graphic display On	step
		25-29	Graphic display Off	step
		30-49	Reserved	
		50-54	Dimmer curve: Square law	step
		55-59	Dimmer curve: Linear	step
		60-64	Fans mode: Auto	step
		65-69	Fans mode: High	step
		70-89	Reserved	
		90-94	Pan/Tilt speed mode	step
		95-99	Pan/Tilt time mode	step
		100 - 104	Blackout while pan/tilt moving	step
		105 -109	Disabled blackout while pan/tilt moving	step
		110-114	Blackout while colour wheels moving	step
		115 -119	Disabled blackout while colour wheels moving	step
		120-139	Reserved	step
			<i>To activate following functions, stop in DMX value for at least 3 seconds.</i>	
		140 - 149	Pan/Tilt reset	step
		150 - 159	Colour wheels reset	step
		160 - 169	Gobo wheels + iris reset	step
		170 - 179	Reserved	
		180 - 189	Zoom/focus/frost/prism reset	step
		190 - 199	Reserved	

DMX protocol

Mode/channel		DMX Value	Function	Type of control
1	2			
		200 - 209	Total reset	step
		210-239	Reserved	
		240	Disable "Quiet mode"	step
		241 - 255	"Quiet mode" - fan noise control from min. to max.	proportional
7	7		Colour wheel 1	
			<i>Continual positioning</i>	
		0	Open/white	proportional
		18	Deep red	proportional
		37	Deep blue	proportional
		55	Yellow	proportional
		73	Magenta	proportional
		91	Green	proportional
		110	Congo blue	proportional
		128-129	White	step
			<i>Positioning</i>	
		130-139	Deep red	step
		140-149	Deep blue	step
		150-159	Yellow	step
		160-169	Magenta	step
		170-179	Green	step
		180-189	Congo blue	step
		190 - 215	Forwards rainbow effect from fast to slow	proportional
		216 - 217	No rotation	step
		218 - 243	Backwards rainbow effect from slow to fast	proportional
		244 - 249	Random colour selection by audio control (Set microphone sensitivity in menu „Personality“)	step
		250 - 255	Auto random colour selection from fast to slow	proportional
8	*		Colour wheel 1 - fine positioning	
		0 - 255	Fine positioning	proportional
9	8		Colour wheel 2	
			<i>Continual positioning</i>	
		0	Open/white	proportional
		18	Light green	proportional
		37	Lavander	proportional
		55	Pink	proportional
		73	CTO	proportional
		91	Blue	proportional
		110	Orange	proportional
		128-129	White	step
			<i>Positioning</i>	
		130-139	Light green	step
		140-149	Lavander	step
		150-159	Pink	step
		160-169	CTO	step
		170-179	Blue	step
		180-189	Orange	step
		190 - 215	Forwards rainbow effect from fast to slow	proportional
		216 - 217	No rotation	step

DMX protocol

Mode/channel		DMX Value	Function	Type of control
1	2			
		218 - 243	Backwards rainbow effect from slow to fast	proportional
		244 - 249	Random colour selection by audio control (Set microphone sensitivity in menu „Personality“)	step
		250 - 255	Auto random colour selection from fast to slow	proportional
10	*		Colour wheel 2 - fine positioning	
		0 - 255	Fine positioning	proportional
11	9		Effect Speed <i>Speed of rot. gobo and static gobo selection</i>	
		0-255	Speed of rot. /static gobo selection from max. to min.	proportional
12	10		Colour wheels time	
		0	Function is off	step
		1 - 255	Time of Colour wheels movement (0.1sec-->25.5sec.)	proportional
13	11		Stat. Gobo+Zoom+Focus+Frost+Iris+Prism time	
		0	Function is off	step
		1 - 255	Time of stat. Gobo, zoom, focus,iris and frost movement (0.1 sec-->25.5 sec.)	proportional
		1-50	Time of prism movement (0.1 sec-->5 sec.)	proportional
14	12		Static gobo wheel	
		0-7	Open/hole	step
		9-17	Gobo 1	step
		18-26	Gobo 2	step
		27-35	Gobo 3	step
		36-44	Gobo 4	step
		45-53	Gobo 5	step
		54-62	Gobo 6	step
		63-71	Gobo 7	step
		72-80	Gobo 8	step
		81-91	Gobo 9	step
			<i>Shaking gobos from slow to fast</i>	
		92-103	Gobo 1	proportional
		104-115	Gobo 2	proportional
		116-127	Gobo 3	proportional
		128-139	Gobo 4	proportional
		140-151	Gobo 5	proportional
		152-163	Gobo 6	proportional
		164-175	Gobo 7	proportional
		176-187	Gobo 8	proportional
		188-199	Gobo 9	proportional
		200 - 201	Open/hole	step
		202 - 222	Forwards gobo wheel rotation from fast to slow	proportional
		223 - 243	Backwards gobo wheel rotation from slow to fast	proportional
		244 - 249	Random gobo selection by audio control (Set microphone sensitivity in menu „Personality“)	step
		250 - 255	Auto random gobo selection from fast to slow	proportional
15	13		Rotating gobo wheel <i>In the range of 0-59 DMX the gobo selection speed can be controlled by the Effect Speed channel.</i>	
			<i>Index - set indexing on channel 16/14</i>	

DMX protocol

Mode/channel		DMX Value	Function	Type of control
1	2			
		0-3	Open/hole	step
		4-7	Gobo 1	step
		8-11	Gobo 2	step
		12-15	Gobo 3	step
		16-19	Gobo 4	step
		20-23	Gobo 5	step
		24-27	Gobo 6	step
		28-31	Gobo 7	step
			<i>Rotation - set rotation on channel 16/14</i>	
		32-35	Gobo 1	step
		36-39	Gobo 2	step
		40-43	Gobo 3	step
		44-47	Gobo 4	step
		48-51	Gobo 5	step
		52-55	Gobo 6	step
		56-59	Gobo 7	step
			<i>Shaking gobos from slow to fast</i>	
			<i>Index - set indexing on channel 17/14</i>	
		60 - 69	Gobo 1	proportional
		70 - 79	Gobo 2	proportional
		80 - 89	Gobo 3	proportional
		90 - 99	Gobo 4	proportional
		100 - 109	Gobo 5	proportional
		110 - 119	Gobo 6	proportional
		120 - 129	Gobo 7	proportional
			<i>Shaking gobos from slow to fast</i>	
			<i>Rotation - set rotation on channel 16/14</i>	
		130 - 139	Gobo 1	proportional
		140 - 149	Gobo 2	proportional
		150 - 159	Gobo 3	proportional
		160 - 169	Gobo 4	proportional
		170 - 179	Gobo 5	proportional
		180 - 189	Gobo 6	proportional
		190 - 199	Gobo 7	proportional
		200 - 201	Open/hole	step
		202 - 222	Forwards gobo wheel rotation from fast to slow	proportional
		223 - 243	Backwards gobo wheel rotation from slow to fast	proportional
		244 - 249	Random gobo selection by audio control (Set microphone sensitivity in menu „Personality”)	step
		250 - 255	Auto random gobo selection from fast to slow	proportional
16	14		Rot. Gobo indexing/rotation	
			<i>Gobo indexing - set position on channel 15/13</i>	
		0 - 255	Gobo indexing	proportional
			<i>Gobo rotation - set position on channel 15/13</i>	
		0	No rotation	step
		1 - 127	Forwards gobo rotation from fast to slow	proportional
		128	No rotation - <u>default</u>	step
		129 - 255	Backwards gobo rotation from slow to fast	proportional

DMX protocol

Mode/channel		DMX Value	Function	Type of control
1	2			
17	*		Rot. Gobo indexing/rotation - fine	
		0-255	Fine indexing (rotation)	proportional
18	15		Prism	
		0 - 19	Open position (hole)	step
		20 - 127	3-facet rotating prism	step
			Prism/gobo macros	
		128 - 135	Macro 1	step
		136 - 143	Macro 2	step
		144 - 151	Macro 3	step
		152 - 159	Macro 4	step
		160 - 167	Macro 5	step
		168 - 175	Macro 6	step
		176 - 183	Macro 7	step
		184 - 191	Macro 8	step
		192 - 199	Macro 9	step
		200 - 207	Macro 10	step
		208 - 215	Macro 11	step
		216 - 223	Macro 12	step
		224 - 231	Macro 13	step
		232 - 239	Macro 14	step
		240 - 247	Macro 15	step
		248 - 255	Macro 16	step
19	16		Prism rotation	
		0	No rotation	step
		1 - 127	Forwards rotation from fast to slow	proportional
		128	No rotation - <u>default</u>	step
		129-255	Backwards rotation from slow to fast	proportional
20	17		Frost	
		0	Open	step
		1 - 179	Frost from 0% to 100%	proportional
		180 - 189	100% frost	step
		190 - 211	Pulse closing from slow to fast	proportional
		212 - 233	Pulse opening from fast to slow	proportional
		234 - 255	Ramping from fast to slow	proportional
21	18		Iris	
		0	Open	step
		1 - 179	From max.diameter to min.diameter	proportional
		180 - 191	Closed	step
			Pulse effects with Iris blackout:	
		192 - 219	Pulse opening from slow to fast	proportional
		220 - 247	Pulse closing from fast to slow	proportional
		248 - 249	Random pulse opening (fast)	step
		250 - 251	Random pulse opening (slow)	step
		252 - 253	Random pulse closing (fast)	step
		254 - 255	Random pulse closing (slow)	step
22	*		Iris - fine	
		0 - 255	Fine iris movement	proportional
23	19		Zoom	

DMX protocol

Mode/channel		DMX Value	Function	Type of control
1	2			
		0 - 255	Zoom from max. to min.beam angle	proportional
24	*		Zoom - fine	
		0-255	Fine zooming	proportional
25	20		Focus	
		0 - 255	Continuous adjustment from far to near	proportional
26	*		Focus - fine	
		0- 255	Fine focusing	proportional
27	21		Reserved	
			Reserved for future functions	
28	22		Shutter/ strobe	
		0 - 31	Shutter closed	step
		32 - 63	Shutter open	step
		64 - 95	Strobe-effect from slow to fast	proportional
		96 - 127	Shutter open	step
		128 - 143	Opening pulse in sequences from slow to fast	proportional
		144 - 159	Closing pulse in sequences from fast to slow	proportional
		160 - 191	Shutter open	proportional
		192 - 223	Random strobe-effect from slow to fast	proportional
		224 - 255	Shutter open	step
29	23		Dimmer intensity	
		0 - 255	Dimmer intensity from 0% to 100%	proportional
30	*		Dimmer intensity - fine	
		0 - 255	Fine dimming	proportional
Copyright © 2015-2016 Robe Lighting s.r.o. - All rights reserved				
All Specifications subject to change without notice				

